



**BRANO a.s., 747 41 Hradec nad Moravicí
The Czech Republic**

tel.: +420/ 553 632 316, 553 632 303
<http://www.brano.eu>; zz-info@brano.eu; info@brano.eu

SAFETY PRINCIPLES, OPERATION AND MAINTENANCE MANUAL FOR

RACK-AND-LEVER JACK

type RZV, lifting capacity 0,8t; 1,6t; 3,2t; 5t and 6,3t

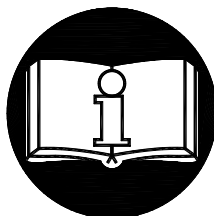
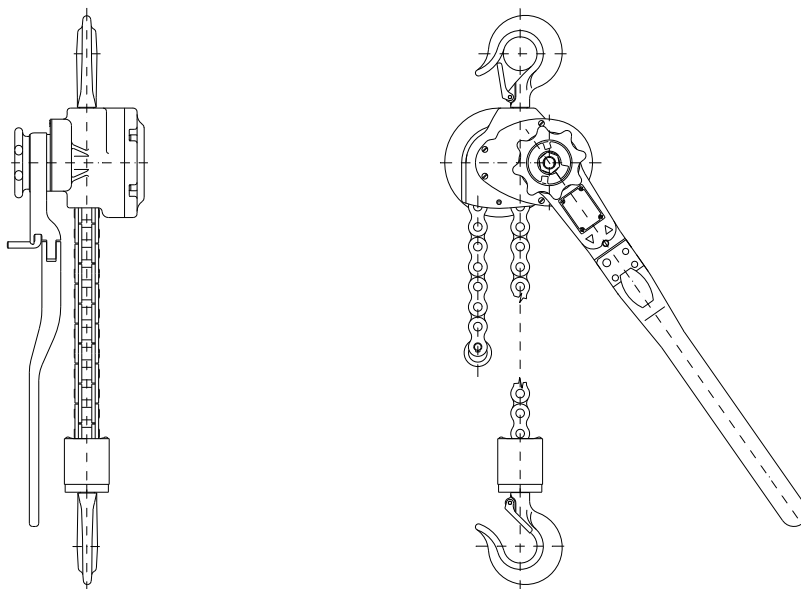

Read this manual carefully before using this product. This manual contains safety, installation, operation and maintenance information. Make this manual available to all responsible persons.

Keep for further use!

Edition 3rd
June 2014
Registration number 1-52197-0-1



CONTENT

1	DEFINITION	3
2	INTENDED PURPOSE	3
3	SAFETY PRINCIPLES	4
3.1	SAFETY SUMMARY	4
3.2	SAFETY PRINCIPLES	4
4	PACKING, STORAGE AND MANIPULATION	6
4.1	PACKING	6
4.2	STORAGE	6
4.3	MANIPULATION	6
5	MAIN TECHNICAL PARAMETERS	6
5.1	MECHANICAL CLASSIFICATION	6
5.2	MATERIAL AND VERSION	7
6	INSTALLATION OF JACK	8
6.1	CHECKING BEFORE THE INSTALLATION	8
6.2	SUSPENSION OF JACK	8
6.3	SETTING THE LENGTH OF CHAIN	8
6.4	POSITION OF THE JACK DURING PULLING	9
6.5	LIFTING (PULLING) OR LOWERING	9
6.6	SAFETY OF JACK – INSTRUCTIONS FOR OPERATOR	9
6.7	CHECKING BEFORE USE	9
7	OPERATION	10
7.1	USE OF THE JACK	10
7.2	SAFETY WORKING ENVIRONMENT	10
8	INSPECTION OF JACK	11
8.1	INSPECTION	11
8.1.1	Inspection classification	11
8.1.2	Daily inspection	11
8.1.3	Regular inspection	11
8.1.4	Occasionally used jack	11
8.1.5	Inspection record	12
8.2	INSPECTION PROCEDURE	12
9	TROUBLE SHOOTING	14
10	LUBRICATION	14
10.1	GENERALLY	14
10.2	GEARINGS	14
10.3	CHAIN	14
11	MAINTENANCE	15
11.1	SAFETY PRINCIPLES	15
11.2	CHAIN – see article 10.3	15
11.3	BRAKE ASSEMBLY	15
11.4	BRAKE ADJUSTMENT	16
11.5	GENERAL INSTRUCTIONS	16
11.6	INSPECTION	16
11.7	REPAIR	17
11.8	TEST	17
12	REMOVING FROM OPERATION – LIQUIDATION	17
13	RELATED DOCUMENTATION	17
14	FINAL REQUIREMENTS OF THE MANUFACTURER TO A CUSTOMER	17

1 DEFINITION

! DANGER

Danger: is used to indicate the presence of a hazard which will cause a death or severe injury if the warning is ignored.

! WARNING

Warning: is used to indicate the presence of a hazard which can cause death or severe injury if the warning is ignored.

! CAUTION

Caution: is used to indicate the presence of a hazard which can cause minor injury if the warning is ignored. Caution can also indicate dangerous practices.

Lifting capacity (Q): indicates maximum mass of load (working load limit) the jack is designed to support in general service under conditions given by this manual.

2 INTENDED PURPOSE

2.1 Rack-and-lever jack type RZV, lifting capacity 0,8t; 1,6t; 3,2t; 5t and 6,3t (further only jack) is designed solely for manual lifting, lowering and pulling of free loads in arbitrary direction on the workplace. The mass of load during lifting or chain tension must not exceed nominal lifting capacity.

2.2 The product has been designed in compliance with the requirements stipulated by Directive 2006/42/EC of the European Parliament and of the Council, as amended by the Czech technical regulation – Government Directive No. 176/2008 Coll., as amended, and the requirements of the harmonized Czech technical standards ČSN EN ISO 12100 and ČSN EN 13157+A1.

2.3 The product has been designed in compliance with the requirements stipulated by Directive 94/9/EC of the European Parliament and of the Council, as amended by the Czech technical regulation – Government Directive No. 23/2003 Coll., as amended. The product has been designed as  **II2c** equipment pursuant to ČSN EN 13463-1:2009 and ČSN EN 13463-5:2012. It complies with the conditions stipulated for use in mining environments classed as “hazardous atmospheric conditions 2” pursuant to ČSN EN 1127-2.

2.4 The product has been designed in compliance with the requirements stipulated by Directive 94/9/EC of the European Parliament and of the Council, as amended by the Czech technical regulation – Government Directive No. 23/2003 Coll., as amended. The product has been designed as  **II2GDcT85°C** equipment pursuant to ČSN EN 13463-1:2009 and ČSN EN 13463-5:2012. It complies with the conditions stipulated for use in environments classed as „zone 1 and zone 21“, “ zone 2 and zone 22“ pursuant to ČSN EN 1127-1.

Note: Articles 2.3 and 2.4 are valid for the version of jack to the environment explosion risk.

3 SAFETY PRINCIPLES

3.1 SAFETY SUMMARY

Danger exists when loads are lifted, particularly when the jack is not being used properly or is poorly maintained. Because an accident or serious injury could result, special precautions apply to the operation with jack, during its assembly, maintenance and inspection.

! WARNING

NEVER use jack for lifting or transporting people.

NEVER lift or transport loads over or near people.

NEVER lift more than lifting capacity shown on the jack.

ALWAYS make sure the load carrying structure will provide adequate support to handle fully loaded jack and all lifting operations.

ALWAYS let people around to know when lift is about to begin.

ALWAYS read the operation manual and safety instructions.

Remember proper rigging and lifting techniques are the responsibility of the operator. Check all applicable national directions, regulations and standards for further information about the safe use of your jack.

3.2. SAFETY PRINCIPLES

! WARNING

3.2.1 Before use

ALWAYS ensure physically strong, qualified and instructed persons elder 18 years of age, knowing this manual and trained in safety conditions and way of work operate the jack.

ALWAYS check the jack every day prior to starting the work according to the article 8.2.(1) „Daily inspection“.

ALWAYS make sure the length of chain is long enough for the intended job.

ALWAYS use original chain only.

ALWAYS ensure the chain was not corroded, clean and oiled.

ALWAYS make sure the end stop (anchor) is firmly fasten on the last chain link or to jack body (for two fall versions).

NEVER pull loads firmly fixed or of unknown weight.

NEVER apply a tension without a necessary knowledge of tensioning forces.

NEVER pull loads firmly fixed or of unknown weight.

ALWAYS check the function of the brake before starting the work (see art. 8.2 (2) point 6.)

NEVER connect or lengthen the chain.

- NEVER** use jack with jumped out, damaged or missing safety latch.
- NEVER** use a jack without the visible marking of the lifting capacity.
- NEVER** use modified or deformed hooks.
- NEVER** use a jack marked by the label „**OUT OF SERVICE**“.
- ALWAYS** consult use of the jack in non-standard or extreme conditions with manufacturer or the authorised representative.

3.2.2 While operation

- ALWAYS** make sure the load properly seats in the hook.
- ALWAYS** make sure the safety latches work in a correct way.
- ALWAYS** pay attention to the limit positions.
- ALWAYS** use manual power only. Do not lengthen the lever.
- ALWAYS** we recommend two people operate the jack when lifting a load of mass close to nominal lifting capacity due to the size of operating forces. When pulling loads ensure the jack in such a way, the jack could not fall during sudden release of a load.
- NEVER** use the jack for anchoring loads.
- NEVER** allow swinging the load, causes impacts or vibrations.
- NEVER** use the chain as a sling.
- NEVER** suspend the load on the tip of the hook.
- NEVER** pull the chain over any edge.
- NEVER** weld, cut or provide any operations on suspended load.
- NEVER** use the chain as a welding electrode.
- NEVER** operate the jack, when the chain starts jumping or excessive noise occurs.

3.2.3 After use

- NEVER** leave a load suspended.
- ALWAYS** ensure the jack against incompetent use.

3.2.4 Risk analysis

Analysis of possible risks as far as the design, operation and work environment of the jack is concern is mentioned in separate document “Risk analysis”. This document is available on request in service centres.

3.2.5 Maintenance

- ALWAYS** let qualified personnel inspect the jack regularly.
 - ALWAYS** ensure the chain was clean and oiled.
 - ALWAYS** ensure the sliding parts were greased enough.
 - NEVER** add or weld other parts for chain elongation
- During maintenance only such measures can be done that will be in conformity with requirements of the manufacture, mentioned in chapter 11 and 14 of this manual.
- It is not allowed** to provide repairs and maintenance in a different way then specified by the manufacturer. It is especially prohibition of use of no original parts or providing changes of product without the agreement of manufacturer.

4 PACKING, STORAGE AND MANIPULATION

4.1 PACKING

4.1.1 The jacks are supplied assembled, packed in paperboard boxes.

4.1.2 Part of the supply is the following documentation:

- a) Instruction manual
- b) EC declaration of conformity
- c) Certificate of quality and completeness of product and warranty card.
 - c1) Warranty period is stated in warranty card.
 - c2) Warranty does not cover defects caused due to neglecting instructions mentioned in the manual and defects caused by the improper use and malpractice interference.
 - c3) Warranty does not cover changes of the product or use of the non-original spare parts without the agreement of the manufacturer.
 - c4) A claim for defects in the product must be applied according to the relevant provisions of the Commercial Code or the Civil Code, as amended.
- d) List of service centre (only for the Czech and Slovak republic)

4.2 STORAGE

Store jacks in dry and clean stores free from chemical influences and vapours.

- (1) ALWAYS store jack without suspending any load on it.
- (2) Remove all dust, water and impurities from the jack.
- (3) Lubricate chain, pivots and springs of safety latches of hooks.
- (4) Suspend the jack in a dry place.
- (5) During the further use follow instructions čl.8.1.2 „Daily inspection“ and 8.1.4 „Occasionally used jack“.

4.3 MANIPULATION

During manipulation observe valid technical regulations and standards for manipulation with heavy loads.

5 MAIN TECHNICAL PARAMETERS

Type	Lifting capacity (t)	Number of chain falls	Operating force (N)	Lifting ¹⁾ speed (m/min)	Range of working temperature	Basic ²⁾ lift (m)	Weight (kg)
RZV	0,8	1	400	1,27	-20°C up to +50°C	1,5	9,5
	1,6	1	370	0,52			17
	3,2	2	370	0,26			24,5
	5	3	440	0,22			41
	6,3	4	430	0,17			46

Notes:

- 2) Calculated on presumption 48 swings of the hand lever per minute.
- 3) Maximum standard lift is 15m. Required lift is necessary to specify in the order.
Lifts over 15 m must be consulted with the manufacturer.

5.1 MECHANICAL CLASSIFICATION

Safety and life of jack is guaranteed under presumption it works in accordance with the specified classification.

Jack is designed for class 1Bm according to the regulation FEM 9.511 – see diagram 5.1. (corresponds to the classification of the mechanism M3 according to the ISO 4301/1). Average daily working time is set by the loading diagram.

Diagram 5.1 MECHANICAL CLASSIFICATION

Load diagram (Load distribution)	Definitions	Cubic mean value	Average daily operating time (h)
1 (light)	Mechanisms or parts thereof, usually subject to very small loads and in exceptional cases only to maximum loads.	$k \leq 0,50$	1 - 2
2 (medium)	Mechanisms or parts thereof, usually subject to small loads but rather often to maximum loads.	$0,50 < k \leq 0,63$	0,5 - 1
3 (heavy)	Mechanisms or parts thereof, usually subject to medium loads but frequently to maximum loads.	$0,63 < k \leq 0,80$	0,25 – 0,5
4 (very heavy)	Mechanisms or parts thereof, usually subject to maximum or almost maximum loads.	$0,80 < k \leq 1,00$	0,12 – 0,25

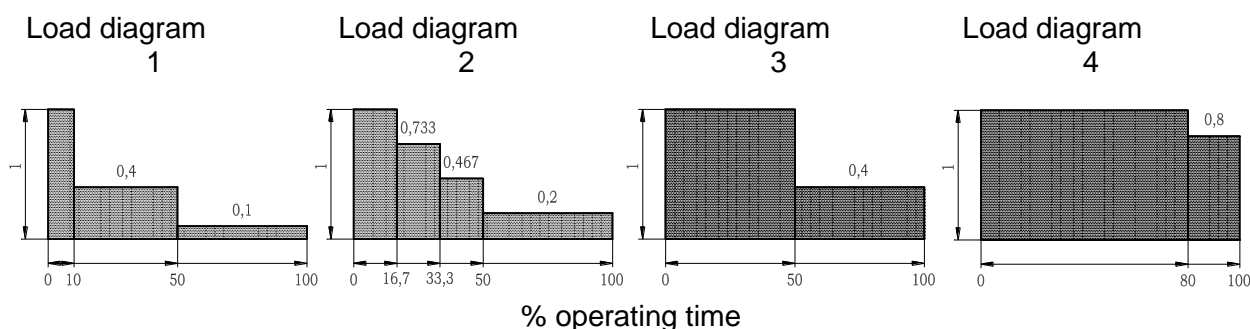

5.2 MATERIAL AND VERSION

5.2.1 All parts of the jack are made of steel and cast iron, brake inserts of brass or metal-ceramic material.

5.2.2. Materials susceptible to the creation of an incentive spar in accordance with of the annex no.2 article 1.3.1 to the ministerial order no.23/2003 collection of laws and harmonized technical standards ČSN EN 1127-2 article 6.4.4, ČSN EN 1127-1 čl.6.4.4 and ČSN EN 13 463-1 article 8.1. are not used.

5.2.3. Materials with dangerous effects of static electricity in accordance with ČSN EN 1127-2 article 6.4.7, ČSN EN 1127-1 article 6.4.7, ČSN EN 13463-1 article 7.4.3 and ČSN 33 2030 are not used in the jack.

5.2.4 The jack does not exceed the noise value specified in the annex no.1 article 1.7.4.2 letter u NV 176/2008 collection of laws (directive EP and RE no.2006/42/EC).

Note: Articles 5.2.2 and 5.2.3 apply for configuration of jack to the environment with explosion risk.

5.3 DATA ON THE PRODUCT

Every single product is fitted with the label, where the following data are stated:

Standard version:	Version for environment with explosion risk:
manufacturer designation	manufacturer designation
address of manufacturer	address of manufacturer
type of product	type of product
lifting capacity	lifting capacity
serial number	serial number
year of production	year of production
CE marking	CE marking
	sign of protection type (I IM2c for group I , II2GDcT85°C for group II)

6 INSTALLATION OF JACK

Prior to installing and usage of the jack, inspect it carefully for possible damages.

6.1 CHECKING BEFORE THE INSTALLATION

6.1.1 Load-carrying structure

! WARNING

ALWAYS make sure the load-carrying structure is firm enough to support the weight of load and jack. The installation must not be provided onto the structure, where the load-carrying capacity cannot be checked.

ALWAYS the user is responsible for the load-carrying structure!

6.2 SUSPENSION OF JACK

! CAUTION

Be careful during suspending a jack on the pendant element and ensure appropriate conditions for suspending according to the environment character (working platform, auxiliary lifting device, etc.), to avoid endanger or injury of people. Use safety equipment when suspending jack in heights to avoid a fall from height.

The user is responsible for creating conditions and providing the installation of the jack.

6.2.1 Lubrication of chain

Put the thin layer of oil on chain preferably by the help of spray. Regular lubrication will avoid wear and corrosion of chain and lengthen its life.

6.3 SETTING THE LENGTH OF CHAIN

We usually need to set the length of chain (span of hooks) to required distance for suspending hooks before lifting or pulling.

Set the selector level (1) on hand lever (2) to the neutral position – see fig. 6.3. At this position of the selector lever you can rotate with hand wheel (4) and move with chain in both directions.

fig.6.3 Setting the length of chain

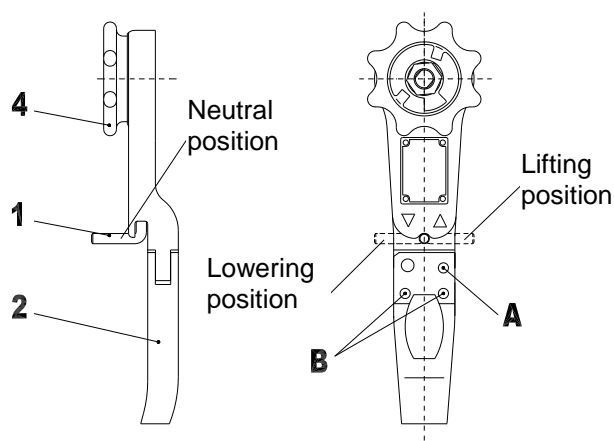

6.4 POSITION OF THE JACK DURING PULLING

The jack must be installed in such a way, the axes of hooks and chain under load were in one straight line.

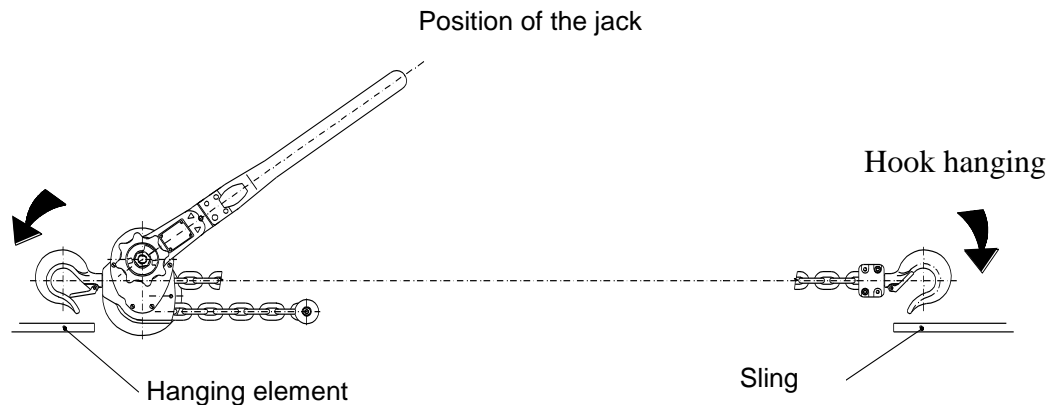

6.5 LIFTING (PULLING) OR LOWERING

Before lifting pull out the selector lever and set it to mark lifting – arrow up (see fig. 6.3). Provide lifting by the pendulous motion of the hand lever. On the beginning of lifting prior to tensioning of the chain, hold the hand wheel so as not to be taken along by lever during its reverse motion.

Prior to lowering of a load or releasing tensioned chain move the selector lever to the position on mark lowering – arrow down (see fig. 6.3). By pendulous motion of the hand lever lower the load or release the tensioned chain.

During any change of position of the selector lever make sure the selector lever properly fit into the bed in the hand lever.

The first motion of hand lever after the change of chain motion (after moving of selector lever) is slightly blocked. This situation happen due stronger tightening of the brake, especially when heavier loads are manipulated. In this case release brake by the energetic motion of hand lever and at the same time unblock hand lever.

6.6 SAFETY OF JACK – INSTRUCTIONS FOR OPERATOR

Lifting and lowering can be interrupted in any height of lift. The stability of the load position is ensured by the lamella brake. The jack is ensured against overloading by the shear pin (A) in the hand lever. When shearing the shear pin the position of a load remains stabilised. With sheared pin the load can be safely lowered only. Two spare shear pins (B) are placed in openings of the hand lever (see fig. 6.3).

From the safety reasons it is not allowed to use other than origin shear pins.

6.7 CHECKING BEFORE USE

! CAUTION

- (1) Firstly look again to the previous articles of this manual and make sure all steps were correctly done and all parts are safely assembled.
- (2) Check, whether hooks are correctly suspended and safety latches are snapped.
- (3) Check visually load carrying construction or the suspending elements, whether they are without defects.
- (4) By several motions of hand lever check the function without a load.
- (5) Provide several lifting and lowering with a suitable load (10% to 50% of lifting capacity). At the same time check the brake, whether during lowering and stopping is the load kept without slipping.

7 OPERATION

7.1 USE OF THE JACK

The jack is multiuse device, determined for lifting, lowering and pulling of loads at a workplace. Can be used not only in standard environment but also in environment with explosion risk, if the label is marked with symbol of protection type – see articlel.2.3, 2.4 and 5.3 of this manual.

It is operated solely by the help of hand lever. It is determined for organisation as well as for private persons. Since dealing with heavy loads may involve unexpected danger, all the “Safety instructions” according to the chapter 3 must be followed.

! WARNING

Do not continue to operate if the chain stopper (anchor) or lower block (at two fall types) contacts the jack’s body. Damage of the chain stopper (or lower block) can lead to the fall of the load. During pulling or tensioning sudden movement of the load can happen and thus release and fall of the unsupported jack. Take therefore a special care.

! WARNING

In exceptional cases, when using jacks with a long lift (15m and more) dangerous heating of the brake during lowering of loads can occurs (uninterrupted and quick lowering). In this cases it is necessary to lower the load slowly with interruptions.

! WARNING

NEVER suspend a load on jack without prior active pre-lifting of a load by the jack. A fall of a load could happen due to insufficiently tight brake.

! CAUTION

When lifting loads that are to be suspended over to another lifting device (crane, fork lift, etc.) it is necessary to unload the load chain (chains) by hand lever of the jack, not lifting the load by another lifting device. Only the above mentioned procedure ensure problems free releasing of the jack’s brake after removing a load.

7.2 SAFETY WORKING ENVIRONMENT

! WARNING

- (1) The operator must be provably familiar with this manual, keep valid safety and hygienic regulations and must be authorised to operate this device.
- (2) Operator must be equipped with helmet, gloves and protective shoes.
- (3) Only verified binding means of appropriate lifting capacity is to be used for binding loads.
- (4) When more persons take part in the operation, always one responsible person, familiar with safety instructions, must be determined for manipulation with the jack.
- (5) The operator must have a clear and unobstructed view of the working area before starting the work. If this is not possible, a second or more persons must serve in the nearby area.
- (6) The operator must check the entire work place is safe and whether the is a possibility of escaping in case of endanger before operating the jack.

- (7) During works with the jack a suitable distance between operator and load must be kept. It is prohibited to lift or lower bulky loads that makes impossible to keep sufficient distance.
- (8) When operating the jack in limited areas you must prevent the hook or load do not contact into any obstacle or to the body of the jack.

8 INSPECTION OF JACK

8.1 INSPECTION

8.1.1 Inspection classification

(1) Initial inspection: prior to initial use. All new or repaired jacks shall be inspected by designated qualified person to ensure compliance with the applicable provisions of this manual.

(2) Inspection procedure for jacks in regular service is divided into two general classifications based on the intervals of inspections. Intervals of inspections depend on the condition of the critical components and the degree of their wear deterioration or malfunction. The respective intervals are defined in the following way:

(a) Daily inspection: visual examination provided by the operator designated by the user on the beginning of each usage.

(b) Regular inspection: visual inspection provided by the operator designated by the user.

- 1) normal service – annually,
- 2) heavy service – semi-annually,
- 3) special or infrequent service – according to the recommendation of the competent person at first usage and according to the directions of the qualified service personnel (maintenance worker).

8.1.2 Daily inspection

Items such as those recommended in paragraph 8.2(1) „Daily inspection“ should be inspected for damages and defects. Provide this inspection also during operation in the interval between regular inspections. A designated personnel shall determine, whether any defects or damages constitute a hazard and whether more detailed inspection is necessary.

8.1.3 Regular inspection

Complete inspections of jacks shall be performed as recommended regular inspections. During these inspections the jack can stay on its usual place and dismantling is not necessary. Recommended regular inspection stated in paragraph 8.2(2) must be provided under supervision of the designated personnel to determine whether the disassembly is necessary. These inspections shall include the requirements of daily inspection.

8.1.4 Occasionally used jack

- (1) A jack which has been idle for a period of one month or more but less than one year before returning to service shall be given an inspection conforming to the requirements of paragraph 8.1.2.
- (2) A jack which has been idle for a period of one year shall be given an inspection conforming to the requirements of paragraph 8.1.3 before it is placed in service.

8.1.5 Inspection record

Always keep records about the performed checks, repairs, inspections and maintenance of jacks. Dated records should be maintained in time intervals specified in paragraph 8.1.1 (2)(b) and keep them on place determined by the user.

Defects found by the inspection or recorded during work must be announced to the person responsible for safety and determined by the user.

8.2 INSPECTION PROCEDURE

(1) Daily inspection (provided by the operator or responsible person)

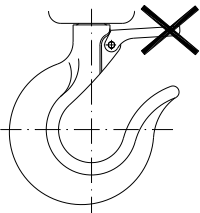
PART	INSPECTION METHOD	LIMIT/CRITERIA FOR DISCARD	REMEDY
1. Function of jack	Visual, hearing	Chain binds, jumps, make an excessive noise, etc.	Clean and lubricate the chain, if defects is not removed, replace the chain.
2. Fastening parts	Visual check of all screws, nuts, rivets, etc.	Defective or missing parts. Unfasten parts.	Replace by new one. Fasten released parts
3. Hooks (1) Appearance	Visual 	Safety latch jumped out of the top of hook, bind shank, other visible deformation of hook	Professional inspection of lifting device – replacing of hook and other damaged parts
(2) Hook rotating	Turn the hook around its axes	Hook does not rotate fluently or jammed	Clean up and lubricate.
(3) Safety latch	By hand spring of latch	Safety latch does not return after pushing.	Clean, lubricate, repair or replace.
4. Load chain (1) Appearance	Check visually the whole chain	Deformation, excessive wear, rust.	Replacement of the chain
(2) Lubrication	Visual	Chain is not lubricated	Clean and lubricate the chain

(2) Regular inspection (provide by the qualified personnel)

PART	INSPECTION METHOD	LIMIT/CRITERIA FOR DISCARD	REMEDY
1. Fastening parts	Visual check of all screws, nuts, rivets, etc.	Defective or missing parts. Unfasten parts	Replace by new Fasten released parts
2. All parts	Visual check	Wear or damaged parts Contaminated or not lubricated parts	Replace by new Dismantle, clean, lubricate and assemble again

3. Name plate – marking of lifting capacity on jack	Visual check	Illegible lifting capacity	Repair or replace by the new one Repair marking on jack
4. Hooks (1) Deformation of hook (opening)	Measure dimension „C“ with slide calliper Visual check	Measured value is bigger than set by the diagram Deformation is visible at visual check	Professional inspection of jack – replacing the hook and other damaged parts
(2) Hook wear	Measure dimension „A“ and „B“ with slide calliper	Do not use hook if dimensions „A“ or „B“ decreased more than 10%	Worn or deformed hook replace by the new one

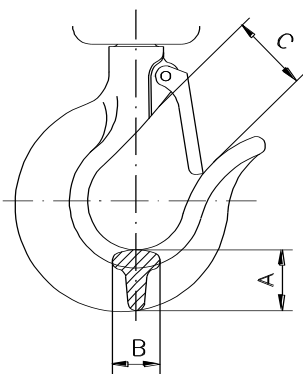

Capacity (t)	Dimension "A" (mm)		Dimension "B" (mm)		Dimension "C" (mm)
	Standard	Limit	Standard	Limit	Limit
0,8	22	19,8	19	17	29
1,6	26	23,4	23	20	35
3,2	36,5	32,8	34	30,5	41
5	42	37,8	35	31,5	45
6,3	58	53	45	41	52

5. Chain - elongation	Measuring of pitch with slide calliper, measure in place that is most often in contact with pulley and nut.	Dimensions „t“ must not exceed limit values shown in the following diagram.	If limit values exceed, ask for replacing the chain.
-----------------------	---	---	--

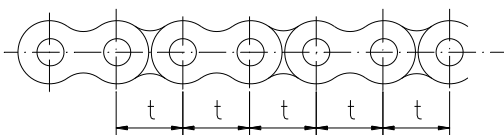

Capacity (t)	Number of measured links	Load at measuring (N)	Pitch of measured links t x 5	
			Standard	Limit
0,8	5	800	97,5	100,5
1,6 to 6,3	5	1600	127	130,8

6. Brake - function	Suspend a load equal to nominal lifting capacity, lift it at min. about 250 mm and lower it.	After interruption of operation, the brake must keep the load in any position of lifting or lowering	If this does not happened, ask for repairing and adjusting the brake.
7. End stop (anchor) of chain	Visual check	End stop is not fasten enough to the chain	Opened (exchange) cotter pin, exchange damaged connecting pin
8. Ratchet pawl - function	Visual check during lifting	Ratchet pawl does not jump behind the teeth of ratchet wheel	Clean, lubricate or replace the spring

9 TROUBLE SHOOTING

Situation	Cause	Remedy
1. Jack does not keep up load.	Brake slipping.	Setting the brake or repair according to the chapter „Maintenance“.
2. Jack lift hard or does not lift a load.	(1) Jack is overloaded. (2) Damaged gear transmission.	(1) Reduce weight of load to nominal lifting capacity. (2) Check parts according to the chapter „Maintenance“.
3. Chain runs improperly, it is jamming.	Damaged or worn out chain or nut.	Check the chain or parts according to „Regular inspection“ or provide repair according to chapter „Maintenance“.
4. Jack emits a special sound.	(1) Insufficiently lubricated chain. (2) Insufficiently lubricated gear transmission.	(1) Lubricate the chain. (2) Lubricate gear transmission with grease.
5. Characteristic sound is not heard when snapping the pawl into the tooth of ratchet wheel.	Loss of pawl function. Rust, impurities, broken spring.	Clean, replace the spring.
6. Safety latch.	(1) Damaged safety latch. (2) Deformed hook.	(1) Repair safety latch. (2) Check the hook – see „Daily inspection“.

10 LUBRICATION

10.1 GENERALLY

Prior to application of the new lubricant, remove the old one, clean parts with a solvent degreaser and apply the new lubricant. Use grease specified by the manufacture.

10.2 GEARINGS

Remove the cover on the opposite side of the hand lever. Remove the old lubricant and substitute by the new one. Use grease: Universal lithium plastic lubricant, water resistant, usable in a minimum range of working temperatures from -20°C to +50°C. For example A2, LV2EP.

10.3 CHAIN

10.3.1 Wash the chain properly in degreasing bath (gasoline, kerosene) and dry.

10.3.2 Lubrication of chain can be done in two ways:

a) Dip the chain into lubricant grease for roller chains, heated to 80°C. Leave the chain in hot grease until it warm up to the same temperature. This method is the best and is recommended to grease the chain in this way at least once per half a year (for example during a check or repair of the lifting device).

b) By spraying the oil for roller motorcycle chains (standard operational lubrication).

! CAUTION

The wrong maintenance and insufficient lubrication of the chain can cause a serious accident.

ALWAYS lubricate the chain 1 x per week or often according to the demand of service (see 10.3.2 b)

ALWAYS lubricate more often in a corrosive environment (sea water, sea climate, acids, etc.) than in ordinary circumstances.

ALWAYS use the lubricant for roller motorcycle chains (spray) or machine oil according to the ISO – VG 46 or VG 48 or its equivalent.

11 MAINTENANCE

11.1 SAFETY PRINCIPLES

! WARNING

With exception of the exchange of the chain, only qualified personnel (service organisations) trained in safety and maintenance of these jacks can carry on maintenance, professional inspections and test.

ALWAYS use only parts supplied by the manufacture.

It is not permitted to carry on repairs and maintenance in other way than specified by the manufacturer. It means particularly forbiddance of using unoriginal spare parts or providing changes on the product without the approval of the manufacturer.

ALWAYS check the function of the jack after carrying on the maintenance.

ALWAYS mark damaged or repaired jack with a suitable safety sign (for example: „OUT OF WORK“).

NEVER do maintenance when a load is suspended on the jack.

NEVER work with the jack that is under repair!

11.2 CHAIN – see article 10.3

11.3 BRAKE ASSEMBLY

Bind (unlock) the bend of the lock washer (2) and unscrew the nut (1). Remove gradually lock washer (2), stop (3), hand wheel (4), carrier wheel (5) and hand lever (11). Unscrew cover (6) and remove braking inserts (9a), ratchet wheel (7), braking inserts (9b) and inserts (10). After checking according to the article 11.6 provide assembly in the reverse way. After assembly it necessary to provide brake adjustment according to the article 11.4.

Legend:

- 1- nut
- 2- lock washer
- 3- stop
- 4- hand wheel
- 5- carrier wheel
- 6- covert
- 7- ratchet wheel
- 8- ratchet pawl
- 9a,9b- braking insert
- 10- washer
- 11- hand lever

Fig. 11.3 – Brake assembly

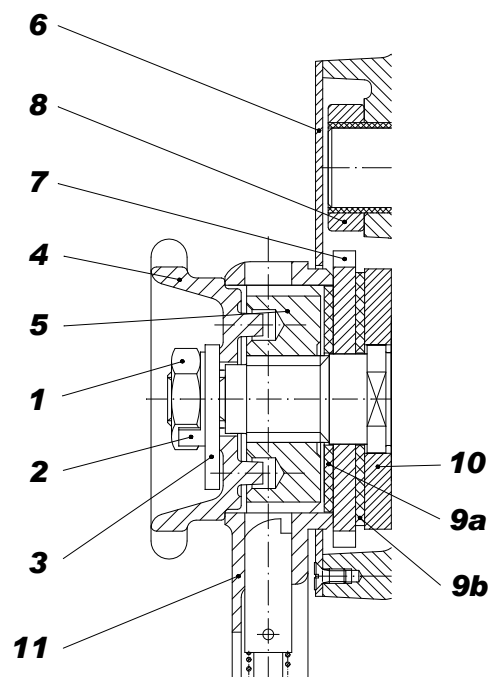

11.4 BRAKE ADJUSTMENT

The stop (3) and dog on hand wheel (2A or 2B) limits the axial clearance in the brake. The angle between the stop and the dog is set by the manufacturer to 50°- see fig. If this angle exceeds value 50° during using of the jack, the brake must be readjust again. The adjustment should be done in the following way: Unscrew the nut (1), remove and turn the stop (3) in such a way to make the required angle with one of dogs (2A or 2B). If this cannot be reached, dismantle hand wheel (4) according to the procedure in article 11.3 and turn it in such a way so as after putting the stop (3) this make the required angle with one of the dogs (2A or 2B). Check the brake with a suitable load.

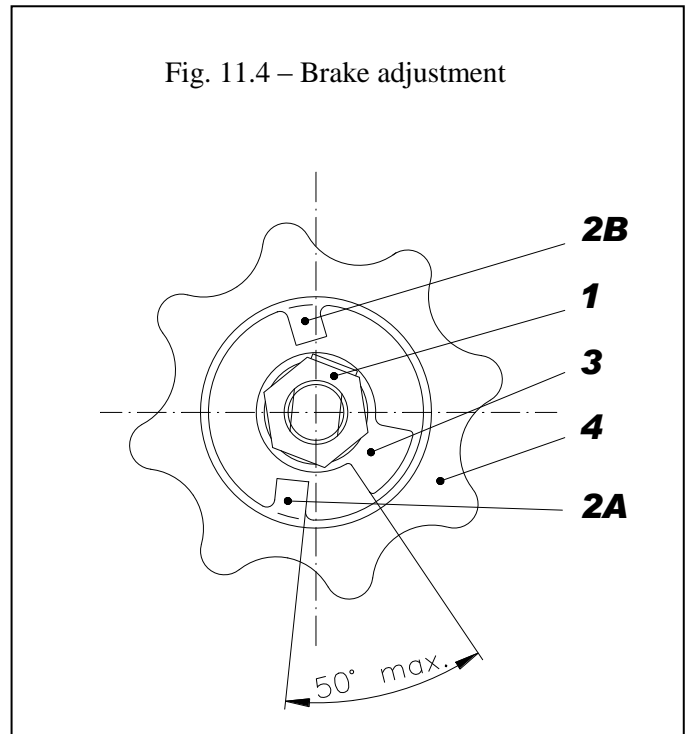

11.5 GENERAL INSTRUCTIONS

The following instructions give general important information about the dismantling, inspection, repair and assembly. If the jack was dismantled from any reason, proceed according to the following instructions.

1. Provide maintenance in the clean environment.
2. **NEVER** dismantle jack more than necessary to provide repair.
3. **NEVER** use excessive force during dismantling parts.
4. **NEVER** use heat as a means during dismantling parts if they are determined for further use.
5. Keep the workplace clean and free from foreign substances that could get into bearings or other moving parts.
6. If you grip a part in a vice, **ALWAYS** use a suitable insert to protect surface of parts.

11.6 INSPECTION

Check all dismantled parts, whether are suitable for further use.

1. Check all gears including the shaft, whether are not worn and are free from scratches or cracks.
2. Check, whether threaded parts have not damaged thread.
3. Brake inserts, ratchet wheel and thrust washer (positions 9a, 9b, 7 and 10 on fig. 11.3) clean with wire brush and check their condition.
4. Measure the thickness of brake inserts (see chart 11.6)

Chart 11.6

Thickness of insert (mm)	Limit (mm)	Wear (mm)
2,5	2	0,5

11.7 REPAIR

Worn or damaged parts must be replaced.

Remove small burrs and scratches or other small surface defects and flatten out with fine grinding stone or abrasive cloth.

11.8 TEST

The load test must be performed at all repaired jacks by the qualified personnel with a load exceeding nominal lifting capacity about 10% to check function and brake of the jack.

12 REMOVING FROM OPERATION – LIQUIDATION

The jack does not contain any harmful substances, its parts are made from steel, cast iron and brass. After removing from operation gives it to firm dealing with liquidation of metal scrap.

13 RELATED DOCUMENTATION

of Law as amended

13.1 EC declaration of conformity

13.2 The instruction manual was elaborated in accordance with the following technical regulations, technical standards and national regulations:

- Ministerial order No.176/2008 of the Coll. of Law as amended (Directive of EP and Council 2006/42/EC)
- Ministerial order No.23/2003 of the Coll. of Law as amended (Directive of EP and Council 94/9/EC)
- ČSN EN ISO 12100
- ČSN EN 13157+A1
- ČSN EN 1127 – 2
- ČSN EN 1127 - 1
- ČSN EN 13463 – 1
- Regulation of CBM (Czech Bureau of Mine) No.22/89 of the Collection of Law
- ČSN 33 2030.

14 FINAL REQUIREMENTS OF THE MANUFACTURER TO A CUSTOMER

Any changes of the product, eventually use of unoriginal spare parts can be realised only based on approval of the manufacturer.

When not observing this condition the manufacturer does not guarantee safety of this product. In such a case the manufacturer warranty does not apply to the product.